

Link-Belt
EXCAVATORS

355 X4S

BROCHURE

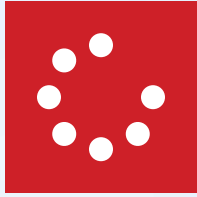



GIVE IT A SPIN

Built upon the solid foundation of our award-winning X4 Series with more capability and intriguing new features, this X4S machine is the largest minimum swing radius excavator in the Link-Belt product line with a weight of around 78,709 lbs. The 355 X4S is versatile enough to suit the expanding demands of increasingly dynamic contractors thanks to a reduced tail swing and lots of control and power. It is perfect for road building and maintenance, home excavation, site preparation, construction, sewage work, and demolition operations.





Link-Belt

355

X4S

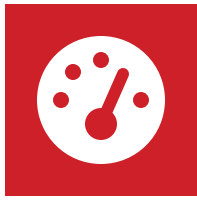

NEXT LEVEL STRENGTH



TOUGH ON DIRT, EASY ON FUEL

Link-Belt Excavators have a long history of saving you money without limiting power or productivity. That's why we run an efficient Isuzu Final Tier 4 Certified engine that delivers 205 horsepower, so you can go the distance and save on fuel. The 355 X4S features superior cycle time, lower fuel consumption, and fuel monitoring at your fingertips. Plus, there's no DPF to maintain, ever.



OPERATOR WORK MODE

Stay in control of fuel economy, productivity, and power depending on the task at hand.

Lifting - Lower engine speed for fine control

Eco - Lower fuel consumption

Power - Normal power mode

Speed Priority - For increased productivity

PERFORMANCE BOOST

We understand your work is essential, and we want to help you get it done right, the first time. We engineer reliability and performance into every piece of equipment, offering advanced lifting performance, pressure relief with constant boost function, preset flow rate and pressure for up to 10 attachments. With optimized pump control and engine speed, you've got unparalleled digging force and working range.



ROBUST POWER

Our exclusive flow control system starts with more digging power, increased lift capacities and rapid cycle times. Kawasaki pumps guarantee hydraulic flow is delivered precisely when and where it's needed. The result is more maneuverability and precision, smoother machine operation and improved fuel efficiency across all operating modes.





IN FULL SWING

When you need to get in and out of a tight spot quickly and effortlessly, rely on the 355 X4S with its minimum swing radius. A smaller swing means safer operability and extra visibility in confined work areas, such as utilities, highway construction, development, and landscaping.

ROOM TO MOVE

- 37% reduced tail swing compared to the 300X4
- 44% reduced tail swing compared to the 350X4

WELL TRAVELED

The 355 X4S is nimble and powerful, yet compact enough to be transported with relative ease. From the comforts of your cab, prioritize flow for swinging and loading, with up to 10.2 rpm.





**CLEVER
CUSTOMIZATION**



CUSTOM FLOW

With throttle volume and frequently used modes conveniently integrated in one panel, our tailored machine function switches provide better operability for digging and loading. No matter the work, the 355 X4S provides customizable operability to meet your needs. Prioritize flow and machine functionality from the comfort of your seat with 4 work modes: lifting, eco, power, and speed priority options.

CUSTOM ATTACHMENT SETTINGS

Store up to 10 distinct attachment settings, customizing the flow rate and pressure you need to get the job done. With tailored attachment operations, lost time and overworking are a thing of the past.

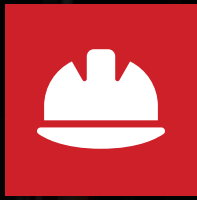

OFFICE WITH A VIEW

The 355 X4S features one of the most spacious, technologically equipped cabs in its class. Joystick control and 4 power modes provide quick customization for the work at hand. Controls are always close with the armrests and joystick conveniently built into the seat height adjustment.





COMFORTS OF HOME

Ergonomic footrest, two-step incline, and foot pedal height are optimized to reduce fatigue on long jobs. Four styles of superior lumbar back support designed to make you feel right at home, even on long jobs. Then, when it's time for a break, adjust your armrest, tilt, or recline up to 155 degrees.

RELY ON RED

Advances in design deliver the best in comfort and safety during operation. The 355 X4S is manufactured with built-in safety features, the WAVES™ system, vertical wide monitor for better visibility, auto operation lever lock function and short tail with reduced swing.



- **MONITOR AND MOVE**

The 355 X4S comes equipped with a 10" HD LCD color monitor, allowing for customizable functions and increased visibility as the WAVES™ system provides a seamless 270° view around your machine. Check detailed fuel information and enable shortcuts for frequently used items, such as machine information, idle mode, auxiliary hydraulics, flow balance and more.

- **WAVES+**

Upgrade jobsite safety with WAVES+. Alerts notify the operator on screen and with an audible sound when movement is detected within the 270° field of view.

- **SAFETY**

The auto lever lock safety function prevents accidents due to unexpected operation of joystick, proportional switch, travel lever and pedal. Additional safety features include firewall, seat belt alarm, LED work lights, neutral safety start, and gate lock safety shutoff.







SUPPORT YOU CAN TRUST

With the purchase of a 355 X4S, you'll get expert service and support with real people. Our Customer Support staff are knowledgeable and happy to assist you with parts, service, and warranty questions.



LINK-BELT PARTS

Your Link-Belt Excavators dealer has a wide range of genuine Link-Belt parts in stock. For anything not on the shelf, our dealers have access to the Link-Belt parts depot - available for lookup online.

MAINTENANCE

All fuel, pilot and oil filters are in one convenient location, including a maintenance-free fuel final filter, making up keep a cinch.





WARRANTY

A comprehensive warranty program and strict quality control are hallmarks of the products we design and manufacture. The quality and durability of the X4S is evident in our 5-year/5,000-hour full machine warranty. Plus, our warranties are transferrable, adding resale value to your equipment purchase decisions. Ask your local dealer about coverage options today.

HASSLE-FREE CARE

Access the radiator compartment or sample and refill hydraulic oil without using any tools and relieve pressure from the hydraulic tank via a handy breather cap. Whenever the cab door is opened, machine hours are displayed for 30 seconds, providing useful information when and where you need it most.





REMOTECARE



The 355 X4S comes standard with a new dual-band modem to improve RemoteCARE communication and functionality with greater range and real-time data capabilities. With 24-hour RemoteCARE®, you'll always know the hours, location, performance, diagnostics and security status of your equipment. Proactively monitor, plan and address preventative maintenance items, receive machine health notifications via email, and review average fuel consumption rates for your machine right from your smartphone.

MINIMIZE DOWNTIME

From minor troubles caused by incorrect machine settings to advanced problem solving, we expand the range of remote support, shorten the lead time for troubleshooting, and reduce costs by moving people.

NO SUBSCRIPTION FEES

RemoteCARE® is available with no subscription fees to the original owner and is transferable.





Link-Belt

WARNING
STAY BACK
200 FT.
All Operators are
Responsible

355 X4S SPECIFICATIONS

SAE Net Horsepower

205 hp (153 kW)

Operating Weight

78,709 lbs. (35,702 kg)

Swing Torque

67,900 lbf-ft (92.1 kNm)



ENGINE

Isuzu AQ-6HK1X Final Tier 4 turbocharged diesel engine with electronic control (ECM) and high pressure common-rail fuel injection, 6-cylinder, water-cooled, Cooled Exhaust Gas Recirculation (EGR), Intercooler, Variable-Geometry Turbocharger (VGT), Diesel Oxidation Catalyst (DOC) and Selective Catalytic Reduction (SCR) system with Dosing Control Module and heated DEF lines and tank. Electronic fuel pump and priming, fuel cooler, auto-idle start, auto warm-up, EPF engine protection, dual-stage fuel filtration, remote oil filter, engine oil sample port, green plug oil drain, double element air filter.

SAE J 1349 net horsepower	205 hp (153 kW) @ 1800 rpm
Displacement	475 cu in (7.8 L)
Maximum Torque	626 lbf-ft (849 Nm) @ 1500 rpm
Starter	24 V - 5.0 kW
Alternator	90 amp
Voltage	24V

CAB AND CONTROLS

ROPS and FOPS Level 1 certified with automatic climate control A/C and heat with defroster, 10" LCD Hi-Definition color monitor with customizable shortcut switches featuring a full time rear view camera display and right view camera, fuel efficiency gauge, custom flow control, joysticks are pre-wired for auxiliary hydraulics, knob switch customization, dual halogen cab lights with programmable delay turn off, safety glass windows, sunroof with sunshade, shockless cab suspension with four fluid cab mounts, SCM High-Back reclining air-suspension seat with heat & tilt, sliding 4-position tilting control consoles, Bluetooth technology, AM/FM sound system with USB and MP3 auxiliary input jack, digital clock, dome light, seat belt, coat hook, 2 cup holders, storage compartments, floor mat, footrests, smart phone tray, 24V socket, 12V outlet, travel alarm, handrails, mirrors, side-entry cab filter, spare parts kit.

Four selectable work modes (SP, Power, Eco, & Lift), RemoteCARE telematics GPS system, anti-theft password protection system, onboard self-diagnostic system with memory and service interval reminders, auto idling system, one-touch decelerator, auto-idle engine shutdown, neutral safety start, gate-lock safety shutoff, top guard OPG level 1 in cab structure.

355 X4S SPECIFICATIONS

HYDRAULIC SYSTEM

Open-center system, (2) variable displacement axial piston pumps, (1) gear pump for pilot controls. Main control valve with one 4-spool valve and one 5-spool valve with auxiliary spool. Internal anti-drift valves for boom and arm, oil cooler, high performance 6-micron full flow return filter, 8-micron pilot filter, firewall and hydraulic free swing.

Hydraulic Pumps

Pump Output	2 x 64.2 gpm (243 L/min)
Pilot Pump Maximum Flow	7.1 gpm (27 L/min)

Relief Valve Settings

Boom Up / Arm / Bucket in Power Boost	4,970 psi (34.3 MPa) 5,410 psi (37.3 MPa)
Swing Circuit	4,410 psi (30.4 MPa)
Travel Circuit	4,970 psi (34.3 MPa)

Hydraulic Cylinders

Number of Cylinders - Bore x Stroke

Boom	2 - 5.5" x 57.5" (140 mm x 1461 mm)
Arm	1 - 5.9" x 65" (150 mm x 1650 mm)
Bucket	5.3" x 42.4" (135 mm x 1078 mm)

SWING

Planetary reduction powered by axial-piston motor, internal ring gear with grease cavity for swing pinion, swing bearing is single-row, shear type ball bearing, mechanical disc swing brake, auto-power swing.

Swing Speed	10.2 rpm
Tail Swing	6'6" (1.98 m)
Swing Torque	67,900 lbf-ft (92.1 kNm)

UNDERCARRIAGE

16'4" (4.98 m) undercarriage by 8'6" (2.60 m) track gauge, sealed and strutted track chain with double track guide, sealed rollers and idlers, disc type brakes, adjustable track tension, swivel guard.

Carrier Rollers	2 per Side
Track Rollers	8 per Side
Track Link Pitch	8.5" (216 mm)
Shoes	48 per Side
Shoe Width	31.5" (800 mm)
Ground Pressure	7.3 psi (0.05 MPa)

355 X4S SPECIFICATIONS

TRAVEL SYSTEM

Two-speed independent hydraulic travel with compact axial-piston motors, hydraulic motor powered output shaft coupled to a planetary reduction drive and track sprocket, all hydraulic components mounted within the width of side frame, automatic downshift for high torque to overcome obstacles, spring-applied hydraulic release parking brake built into each motor, travel motors equipped with counterbalance valve to prevent over-speeding down an incline, single-pedal straight line travel.

Travel Speeds	1.7 - 2.7 mph (2.8 - 4.4 km/h)
Drawbar Pull	60,100 lbf (268 kN)
Gradeability	70% (35°)

ATTACHMENT

Boom	20' 2" (6.15 m)
Available Arms	Digging Force
10' 5" (3.18 m)	28,870 lbf (128.4 kN)
with Auto Power Boost	31,380 lbf (139.6 kN)
8' 8" (2.65 m)	33,050 lbf (147.0 kN)
with Auto Power Boost	35,950 lbf (159.9 kN)
12' 0" (3.66 m)	25,700 lbf (114.3 kN)
with Auto Power Boost	27,940 lbf (124.3 kN)
Bucket Digging Force	39,340 lbf (175 kN)
with Auto Power Boost	42,780 lbf (190.3 kN)

LUBRICANT AND COOLANT CAPACITY

Fuel Tank	100 Gallons (379 Liters)
Hydraulic System	96 Gallons (363 Liters)
Hydraulic Tank	43 Gallons (164 Liters)
Final Drive (per side)	2.5 Gallons (9.5 Liters)
Swing Drive	1.3 Gallons (5 Liters)
Engine Oil	10.8 Gallons (40.9 Liters)
DEF Tank	11 Gallons (43 Liters)
Coolant System	11.6 Gallons (43.8 Liters)

OPERATING WEIGHT

Working weight with 31.5" (800 mm) shoes, 20' 2" (6.15 m) boom, 10' 5" (3.18 m) arm, 2,099 lbs. (952 kg) bucket, 17,500 lbs. (7 959 kg) counterweight.	78,709 lbs. (35 702 kg)
--	-------------------------

355 X4S SPECIFICATIONS

WORKING RANGE

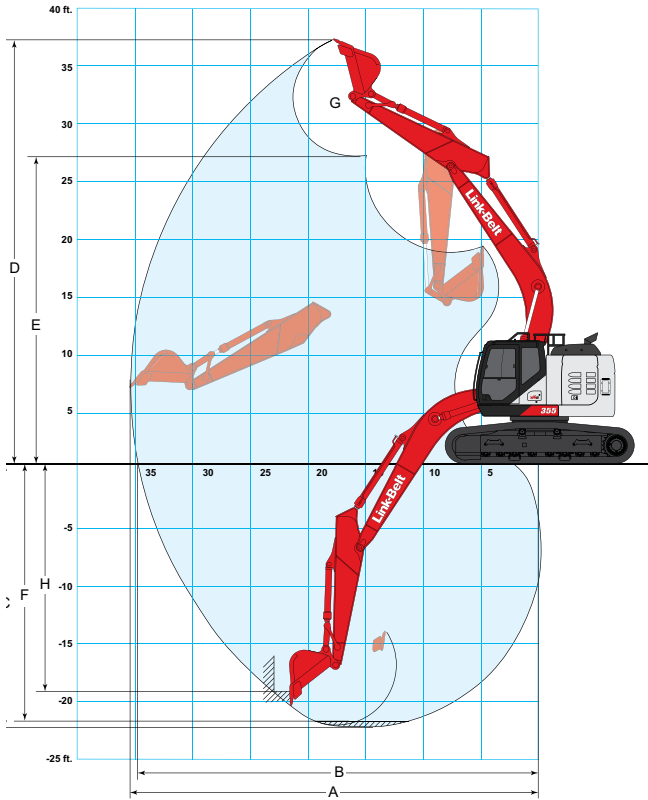

Machine Equipped with 20' 2" (6.15 m) Boom	Arm 10' 5" (3.18 m)	Arm 8' 8" (2.65 m)	Arm 12' 0" (3.66 m)
A. Maximum reach	35' 4" (10.77 m)	33' 10" (10.32 m)	36' 11" (11.26 m)
B. Maximum reach @ ground level	34' 8" (10.57 m)	33' 2" (10.11 m)	36' 4" (11.07 m)
C. Maximum dig depth	22' 10" (6.95 m)	21' 1" (6.42 m)	24' 5" (7.44 m)
D. Maximum dig height	36' 8" (11.17 m)	35' 11" (10.95 m)	37' 11" (11.56 m)
E. Maximum dump height	26' 7" (8.10 m)	25' 10" (7.87 m)	27' 10" (8.47 m)
F. Digging depth 8' (2.44 m) level bottom	22' 3" (6.79 m)	20' 6" (6.24 m)	23' 11" (7.29 m)
G. Bucket rotation	176°	176°	176°
H. Maximum vertical wall depth	19' 8" (5.99 m)	18' 6" (5.64 m)	21' 8" (6.60 m)

TRAVEL DIMENSIONS

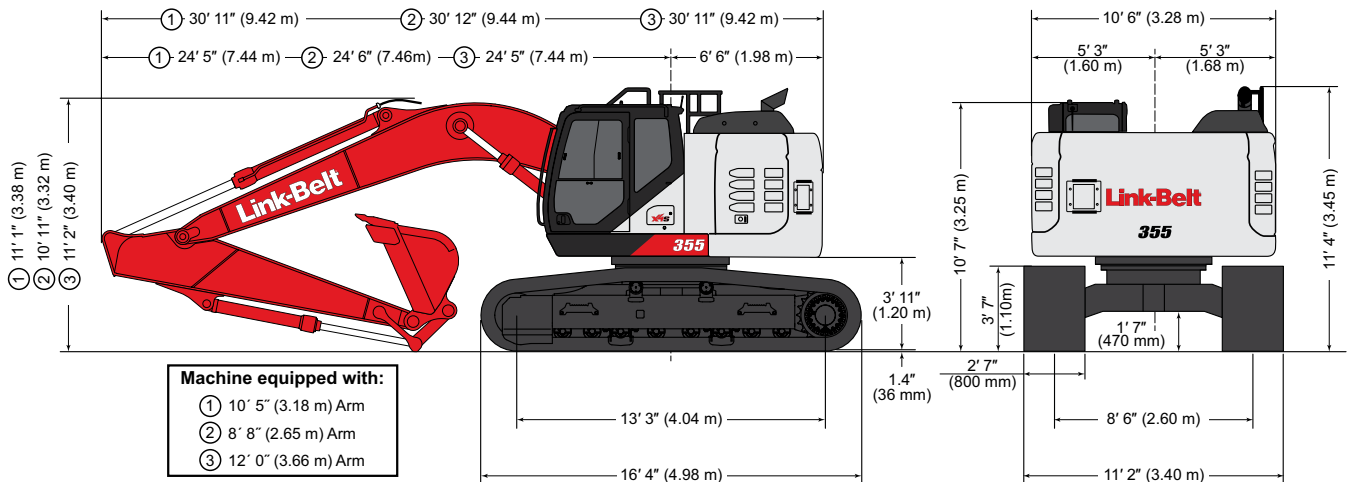

355 X4S SPECIFICATIONS

LIFT CAPACITIES

RADIUS OF LOAD:

10' 5" (3.18 M) ARM WITH 20' 2" (6.15 M) BOOM WITH POWER-BOOST APPLIED

		5' 0" (1.5 m)		10' 0" (3.0 m)		15' 0" (4.5 m)		20' 0" (6.0 m)		25' 0" (7.5 m)		30' 0" (9.0 m)		Cap at Max. Reach	
End	Side	End	Side	End	Side	End	Side	End	Side	End	Side	End	Side	End	Side
+30' 0"	lbs													15,250*	15,250*
(9.14 m)	kg													6,810*	6,810*
+25' 0"	lbs							17,400*	17,400*					13,700*	13,700*
(7.5 m)	kgs							7,880*	7,880*					6,180*	6,180*
+20' 0"	lbs							18,300*	18,300*	17,750*	14,000			13,200*	12,400
(6.0 m)	kg							8,390*	8,390*	8,080*	6,510			5,980*	5,580
+15' 0"	lbs			34,500*	34,500*	24,800*	24,800*	20,800*	19,050	18,750*	13,750			13,250*	11,050
(4.5 m)	kg			16,320*	16,320*	11,530*	11,530*	9,580*	8,820	8,590*	6,380			6,010*	4,980
+10' 0"	lbs					31,800*	27,400	24,050*	18,250	20,350*	13,350			13,700*	10,300
(3.0 m)	kg					14,790*	12,690	11,110*	8,440	9,350*	6,200	7,300*	4,790	6,230*	4,670
+5' 0"	lbs					37,400*	25,900	27,050	17,500	20,650	12,950	15,500*	10,150	14,700*	10,100
(1.5 m)	kg					17,320*	11,670	12,490*	8,090	9,580	6,010	7,380	4,700	6,670*	4,570
Ground	lbs					39,600*	25,150	28,100	16,950	20,300	12,650			16,250	10,300
Line	kg					18,270*	11,670	13,060	7,860	9,420	5,870			7,360	4,660
-5' 0"	lbs			26,200*	26,200*	38,950*	24,950	27,850	16,750	20,150	12,550			17,500	11,000
(1.5 m)	kg			11,560*	11,560*	17,960*	11,580	12,930	7,750	9,350	5,800			7,920	4,990
-10' 0"	lbs			41,650*	41,650*	35,900*	25,100	27,200*	16,750					20,300	12,650
(3.0 m)	kg			18,360*	18,360*	16,590*	11,650	12,590*	7,770	9,390	5,840			9,150	5,710
-15' 0"	lbs			39,700*	39,700*	29,500*	25,600	21,600*	17,200					20,550*	16,550
(4.5 m)	kg			18,460*	18,460*	13,760*	11,870	10,220*	7,940					9,340*	7,380

NOTES: EXCAVATOR LIFTING CAPACITIES

- The lift capacities above are based on the ISO standard, ISO 10567:2007 - "Earthmoving Machinery - Hydraulic Excavators - Lift Capacity"
- Lifting capacities shown should not be exceeded. The weight of all lifting accessories must be deducted from the above lifting capacities. The use of a work tool attachment point as the lift point could affect the machine lift performance.
- Lifting capacities are based on the machine standing on a firm, uniform supporting surface. Users must make allowances for job conditions such as soft or uneven ground.
- Lifting capacities shown do not exceed 75% of the minimum tipping loads or 87% of the hydraulic capacities. Lifting capacities marked with an asterisk (*) are limited by hydraulic capacities.
- The least stable position is lifting over the side.
- Operators should be fully acquainted with the Operator's Manual & Operating Safety Booklet, furnished by LBX Company LLC before operating the machine.
- Lift capacities apply only to the machine as originally manufactured and normally equipped by LBX Company LLC.
- This lift chart is without bucket, bucket cylinder, and bucket linkage. If the machine is equipped with any of these components the weight of those components must be deducted from the listed lifting capacities.

355 X4S SPECIFICATIONS

LIFT CAPACITIES (CONT.)

RADIUS OF LOAD:

8' 8" (2.65 M) ARM WITH 20' 2" (6.15 M) BOOM WITH POWER-BOOST APPLIED

		5' 0" (1.5 m)		10' 0" (3.0 m)		15' 0" (4.5 m)		20' 0" (6.0 m)		25' 0" (7.5 m)		30' 0" (9.0 m)		Cap at Max. Reach	
End	Side	End	Side	End	Side	End	Side	End	Side	End	Side	End	Side	End	Side
+30' 0"	lbs													20,050*	20,050*
(9.14 m)	kg													8,910*	8,910*
+25' 0"	lbs							19,400*	19,400*					17,450*	17,100
(7.5 m)	kgs							8,780*	8,780*					7,880*	7,570
+20' 0"	lbs					22,000*	22,000*	20,000*	19,500	18,250*	13,900			16,650*	13,600
(6.0 m)	kg					10,170*	10,170*	9,180*	9,030	8,760*	6,460			7,540*	6,110
+15' 0"	lbs					27,550*	27,550*	22,400*	18,900	19,950*	13,700			16,650*	11,950
(4.5 m)	kg					12,810*	12,810*	10,320*	8,750	9,140*	6,360			7,550*	5,390
+10' 0"	lbs					34,450*	27,050	25,450*	18,150	21,050	13,400			17,250*	11,100
(3.0 m)	kg					16,020*	12,510	11,770*	8,400	9,770	6,200			7,840*	5,040
+5' 0"	lbs					38,400*	25,800	28,100*	17,500	20,700	13,050			17,050	10,900
(1.5 m)	kg					15,710*	11,950	12,980*	8,100	9,600	6,040			7,740	4,930
Ground	lbs					39,950*	25,300	28,200	17,100	20,450	12,800			17,550	11,150
Line	kg					17,860*	11,740	13,110	7,910	9,470	5,930			7,970	5,050
-5' 0"	lbs			26,400*	26,400*	38,300*	25,250	28,050	16,950	20,350	12,750			19,200	12,050
(1.5 m)	kg			11,590*	11,590*	17,650*	11,730	13,030	7,850	9,440	5,890			8,680	5,470
-10' 0"	lbs			45,400*	45,400*	34,300*	25,500	26,100*	17,100					21,450*	14,200
(3.0 m)	kg			20,890*	20,890*	15,840*	11,850	12,120*	7,910					9,720*	6,400
-15' 0"	lbs					26,150*	26,150*							20,550*	19,800
(4.5 m)	kg					12,270*	12,130							9,370*	8,770

NOTES: EXCAVATOR LIFTING CAPACITIES

- The lift capacities above are based on the ISO standard, ISO 10567:2007 - "Earthmoving Machinery - Hydraulic Excavators - Lift Capacity"
- Lifting capacities shown should not be exceeded. The weight of all lifting accessories must be deducted from the above lifting capacities. The use of a work tool attachment point as the lift point could affect the machine lift performance.
- Lifting capacities are based on the machine standing on a firm, uniform supporting surface. Users must make allowances for job conditions such as soft or uneven ground.
- Lifting capacities shown do not exceed 75% of the minimum tipping loads or 87% of the hydraulic capacities. Lifting capacities marked with an asterisk (*) are limited by hydraulic capacities.
- The least stable position is lifting over the side.
- Operators should be fully acquainted with the Operator's Manual & Operating Safety Booklet, furnished by LBX Company LLC before operating the machine.
- Lift capacities apply only to the machine as originally manufactured and normally equipped by LBX Company LLC.
- This lift chart is without bucket, bucket cylinder, and bucket linkage. If the machine is equipped with any of these components the weight of those components must be deducted from the listed lifting capacities.

355 X4S SPECIFICATIONS

LIFT CAPACITIES (CONT.)

RADIUS OF LOAD:

12' 0" (3.66 M) ARM WITH 20' 2" (6.15 M) BOOM WITH POWER-BOOST APPLIED

		5' 0" (1.5 m)		10' 0" (3.0 m)		15' 0" (4.5 m)		20' 0" (6.0 m)		25' 0" (7.5 m)		30' 0" (9.0 m)		Cap at Max. Reach	
End	Side	End	Side	End	Side	End	Side	End	Side	End	Side	End	Side	End	Side
+30' 0"	lbs							14,400*	14,400*					12,250*	12,250*
(9.14 m)	kg							6,890*	6,890*					5,500*	5,500*
+25' 0"	lbs							15,650*	15,650*	13,000*	13,000*			11,150*	11,150*
(7.5 m)	kgs							7,100*	7,100*	6,370*	6,370*			5,030*	5,030*
+20' 0"	lbs							16,750*	16,750*	16,450*	14,100			10,750*	10,750*
(6.0 m)	kg							7,660*	7,660*	7,480*	6,560			4,870*	4,870*
+15' 0"	lbs					22,250*	22,250*	19,250*	19,200	17,600*	13,800	12,850*	10,450	10,750*	10,100
(4.5 m)	kg					10,330*	10,330*	8,870*	8,870*	8,070*	6,400	6,440*	4,870	4,870*	4,570
+10' 0"	lbs					29,300*	27,750	22,650*	18,300	19,350*	13,350	16,100	10,300	11,050*	9,500
(3.0 m)	kg					13,620*	12,850	10,450*	8,480	8,890*	6,190	7,470	4,770	5,010*	4,310
+5' 0"	lbs					35,550*	26,000	25,900*	17,450	20,600	12,900	15,850	10,050	11,700*	9,300
(1.5 m)	kg					16,480*	12,050	11,970*	8,090	9,560	5,980	7,350	4,660	5,320*	4,220
Ground	lbs			15,150*	15,150*	38,800*	25,000	28,000	16,850	20,200	12,550	15,650	9,850	12,850*	9,450
Line	kg			6,650*	6,650*	17,920*	11,600	13,000*	7,800	9,370	5,810	7,260	4,570	5,810*	4,280
-5' 0"	lbs	15,950*	15,950*	24,250*	24,250*	39,100*	24,650	27,600	16,500	19,950	12,350			14,700*	10,050
(1.5 m)	kg	7,140*	7,140*	10,730*	10,730*	18,040*	11,440	12,840	7,650	9,260	5,710			6,660*	4,540
-10' 0"	lbs	25,850*	25,850*	36,450*	36,450*	36,950*	24,700	27,600	16,450	19,950	12,350			18,100	11,300
(3.0 m)	kg	11,530*	11,530*	16,080*	16,080*	17,060*	11,460	12,810	7,630	9,260	5,710			8,180	5,110
-15' 0"	lbs			43,950*	43,950*	31,800*	25,100	23,800*	16,750					19,500*	14,100
(4.5 m)	kg			20,420*	20,420*	14,790*	11,640	11,130*	7,750					8,850*	6,320

NOTES: EXCAVATOR LIFTING CAPACITIES

- The lift capacities above are based on the ISO standard, ISO 10567:2007 - "Earthmoving Machinery - Hydraulic Excavators - Lift Capacity"
- Lifting capacities shown should not be exceeded. The weight of all lifting accessories must be deducted from the above lifting capacities. The use of a work tool attachment point as the lift point could affect the machine lift performance.
- Lifting capacities are based on the machine standing on a firm, uniform supporting surface. Users must make allowances for job conditions such as soft or uneven ground.
- Lifting capacities shown do not exceed 75% of the minimum tipping loads or 87% of the hydraulic capacities. Lifting capacities marked with an asterisk (*) are limited by hydraulic capacities.
- The least stable position is lifting over the side.
- Operators should be fully acquainted with the Operator's Manual & Operating Safety Booklet, furnished by LBX Company LLC before operating the machine.
- Lift capacities apply only to the machine as originally manufactured and normally equipped by LBX Company LLC.
- This lift chart is without bucket, bucket cylinder, and bucket linkage. If the machine is equipped with any of these components the weight of those components must be deducted from the listed lifting capacities.

355 X4S SPECIFICATIONS

STANDARD EQUIPMENT

CAB

- 270° WAVES Camera System
- 12V Power Outlet
- AM/FM Sound System
- Anti-Theft Device
- Auxiliary Switches on Control Lever
- Cab Air Filter - External
- Cab Handrails
- Cab Interior Light
- Cab ISO-Mounts
- LED Cab Lights
- Clear Roof Window
- Climate Control A/C and Heater
- Cup Holder
- Defroster
- Digital Clock
- Emergency Exit and Hammer
- Face Vent
- Floor Mat (Split)
- Front Window One-Touch Lock
- Gate Lock Hydraulic Activation
- Horn
- Hour Meter (Digital)
- LCD 10" Color Monitor
- Magazine Storage Rack
- Maintenance Interval Reminders
- MP3 Auxiliary Input Jack
- On-Board Diagnostic System
- One-Piece Right Window
- Radio Mute Switch
- Rear View Camera
- Rear View Mirrors (3)
- RemoteCARE Support System (GPS)
- Right View Camera
- Roof Sun Shade

- ROPS Certified Structure
- Safety Glass Windows
- SCM Air-Suspension Seat with Tilt & Heater
- Seat Recline
- Selectable Monitor Languages
- Small Storage
- Smart Phone Tray
- Travel Alarm with Cancel Switch
- Trip Meter (Digital)
- Wiper & Washer
- Wiper Switch on RH Joystick

ENGINE

- 90A Alternator
- Air Filter (Double Element)
- Air Filter Restriction Indicator
- Auto Warm-Up System
- Auto-Idle
- Auto-Idle Engine Shutdown
- Battery Disconnect Switch
- Cooling Fan
- Diesel Oxidation Catalyst (DOC)
- Drain for Fuel Tank
- Dual Remote Fuel Filters with Water Separators
- EGR Coolers
- Emergency Engine Stop
- Engine Oil Sample Port
- Engine Protection Feature
- External Fuel Gauge
- External DEF Gauge
- Fan Housing
- Fuel Cooler
- Fuel Filter Restriction Indicator

- Fuel Management System
- Fuel Usage History
- Fuel Usage Monitor
- Glow Plug Pre-Heat
- Idle-Start
- Intercooler
- Neutral Start
- One-Touch Idle
- Radiator / Oil Cooler / Intercooler Protective Screen
- Remote Engine Oil Drain
- Remote Oil Filter
- Selective Catalytic Reduction (SCR)
- DEF Gauge on Monitor
- VGT Turbocharger

HYDRAULICS

- Anti-drift valves (Arm & Boom)
- Arm Regeneration
- Arm Speed Assistance (2 Pump Flow)
- Attachment Cushion Valve
- Auto Swing Priority
- Custom Flow Control
- Auxiliary Tool Settings (Custom Naming)
- Auxiliary Valve
- Boom Regeneration
- Boom Speed Assistance (2 Pump Flow)
- Bucket Curl Assist
- Control Levers Pre-Wired for Auxiliary Hyd.
- Pattern Control Valve (2 way)
- Electronically Controlled Hydraulic Pumps
- Fire Wall
- Free Swing
- Hydraulic Filter

- Restriction Indicator
- Hydraulic Oil Sample Port
- Long Life Hydraulic Oil (5,000 Hour)
- Neutral Pump De-Stroke
- Oil Cooler
- Power Boost
- Power Save
- Pressure Reading on Monitor
- Pump Stand-By Pressure
- Single Pedal Travel

UNDERCARRIAGE

- 800 mm shoes (31.5 in) 3-Bar Steel
- Double Track Guide
- Lashing Points (Tie-Downs)
- Sealed Link Chain
- Steps
- Strutted Track Chain
- Swivel Guard

UPPERSTRUCTURE

- Center Cover (Over Main CV)
- Fuel Tank Belly Pan
- ISO Guard Rails
- Lockable Fuel Cap and Service Doors
- Lockable Tool Box
- Tool Box Light

ATTACHMENT

- 10' 5" (3.18 m) Arm
- 20' 2" (6.15 m) Main Boom Section
- Auxiliary Pipe Brackets
- LED Boom Light
- Bucket Anti Clatter
- Chrome Pins
- HD Bucket Linkage
- Teardrop Pin Retention Keepers

355 X4S SPECIFICATIONS

OPTIONAL EQUIPMENT

CAB

- 270° WAVES+ Camera System
- Cab Sun Visor (Front)
- FOPS Head Guard (Level 2)
- Front Guard (Mesh)
- Front Guard (OPG Level 1)
- LED Lights for WAVES Cameras
- Rain Deflector
- Vandal Cover (Front Window)

ENGINE

- Reversible Cooling Fan

HYDRAULICS

- Hose Burst Check Valve

AUXILIARY HYDRAULIC OPTIONS

- Multi-Function Aux. w/ in-cab Pressure Settings and Proportional Joystick
- Combination Aux. w/ in-cab Pressure Settings and Proportional Joystick

UNDERCARRIAGE

- 700 mm shoes (27.5 in) 3-Bar Steel
- 850 mm shoes (33.4 in) 3-Bar Steel
- Full Track Guide

ATTACHMENT

- 8' 8" (2.65 m) Arm
- 12' 0" (3.66 m) Arm

BUCKET SIZES



Scan the QR code to find the right size bucket, thumb, and coupler combination for the 355 X4S.

Or visit qrco.de/bcYXH5





Link-Belt[®]

EXCAVATORS

LBX Company

lbxco.com

For more information
- including a digital
version of this
brochure - scan the
QR code.



#LBX2457 · 2/24

LBX[®] and Link-Belt[®] are registered trademarks. Copyright 2022. All rights reserved. We are constantly improving our products and therefore reserve the right to change designs and specifications.