

SAE Net Horsepower: 160 HP (119 kW)
Operating Weight: 48,900 lbs. (22 200 kg)
Digging Depth: 21 ft 10 in (6.65 m)

210x4



Link-Belt

210x4

SPECIFIC

Link-Belt
EXCAVATORS



PERFORMANCE, PRODUCTIVITY AND RELIABILITY COME STANDARD

Link-Belt X4 Series excavators are built to exceed your expectations. New electronically-controlled hydraulic pumps reduce cycle times by as much as 9%. Expect more power and fuel efficiency, thanks to an innovative Final Tier 4 engine that delivers up to 12% improved fuel consumption, **without a Diesel Particulate Filter (DPF) to maintain or replace!** Settle in to the roomiest, most accommodating cab in its class, with more legroom and a new high-back, heated seat for shift-long comfort. Daily maintenance is a snap, with ground-level access to all service points, easily opened by hand.



INNOVATION AND ATTENTION TO DETAILS AT EVERY LEVEL



- Three power modes (Speed Priority, Heavy and Applied Power) let you **choose the best blend of power, precision and fuel savings** for the work you're doing



- EPA Final Tier 4 engine is **fuel efficient without sacrificing power**



- **No DPF** to ever worry about!
- 2-3% DEF (Diesel Exhaust Fluid) consumption rate relative to fuel consumption, combined with one of the largest DEF tank capacities lets you work long hours between refills



- Ground level access to routine service points lets you **cut daily maintenance down to just minutes**



- Quiet, pressurized cab offers **excellent visibility and comfortable, best-in-class seating**
- Enough floor space to **accommodate the largest of work boots**, with cup holders and roomy storage compartments for cell phones, snacks and other personal items



- Dual cab working lights are standard, or choose optional LEDs for **added visibility**



- Ergonomic joysticks **fit your hand perfectly**

- 7" high-definition LCD monitor **keeps you connected to your machine and work environment**



- RemoteCARE® telematics **keeps a watchful eye** on performance, maintenance intervals and theft deterrence



- Full-time, rear-view camera display is standard; add the WAVES™ option for a **seamless 270° view around the machine**

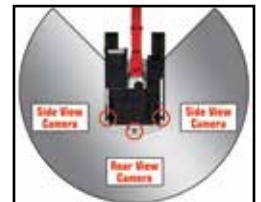

- Structural improvements to the boom and arm **reduce stress and provide greater durability**



- Robust undercarriage features **larger track rollers and thicker plating for longer life**



- Unique side-frame design **reduces dirt accumulation** and is **easier to clean**

- Add Link-Belt **2D Machine Guidance** to **maintain a consistent grade and depth control** for all projects. Choose **2D Machine Control** for semiautonomous digging; operator controls the speed of the stick while the boom and bucket automatically adjust to maintain the target grade.



*All improvements and percentage increases are in reference to Link-Belt X3 Series excavators, unless otherwise stated



QUICK AND RESPONSIVE TO TAKE ON TOUGH CHALLENGES



Greater digging power, increased lift capacities and faster cycle times start with our intuitive Ulti-Flow™ hydraulic system featuring a 30% larger hydraulic passage area, larger spools and advanced controls. Pilot pressure sensors detect the type of work being done—such as digging or leveling—and then relays that data to proportional solenoid valves that quickly determine where optimal hydraulic pressures should be directed for that operation.

Two electronically-controlled Kawasaki variable-displacement axial-piston pumps and one Kawasaki gear pump assure that hydraulic power is delivered precisely when and where it's needed. At the same time, hydraulic flows in noncritical areas of the system are reduced.

The result is better breakout force, more lifting strength and faster machine response. You'll dig, swing and dump quicker than ever before...with up to 9% faster cycle times and improved fuel efficiency!

- Proprietary hydraulic system
- New control valve with larger ports; less restriction means improved hydraulic flow for increased performance
- Electronically-controlled pumps for improved cycle times, quicker response and more efficient machine operation
- Move more dirt per gallon of fuel



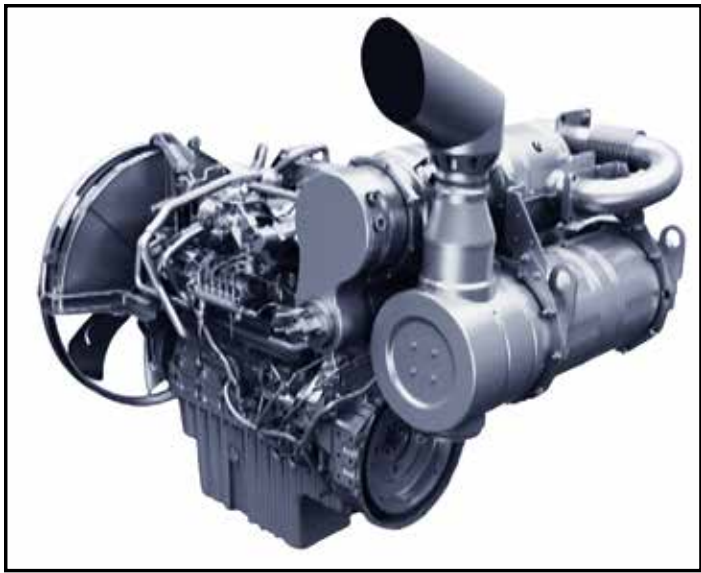

POWER AND EFFICIENCY WITHOUT COMPROMISE

The X4 Series features innovative EPA-certified Final Tier 4 engines from Isuzu that strike the ultimate balance between power, productivity and fuel efficiency. You'll experience up to 12% improved fuel efficiency, without having to worry about costly diesel particulate filters (DPF) to maintain or replace. Three power modes provide reliable power and control for any machine application. Choose Speed Priority (SP mode) to get jobs done quickly, Heavy (H mode) for the best blend of power and fuel savings or Applied Power (A mode), with 13 different RPM settings for precise control of heavy lifting, fine grading or leveling work.

- EPA-certified Tier 4 Final
- No DPF to maintain
- Up to 12% improved fuel economy
- 500-hr. fuel filter service intervals
- 10 diesel tank refills per 1 diesel exhaust fluid (DEF) refill
- 2.5% DEF consumption rate
- Two-stage DEF anti-freeze system for protection in harsh operating conditions
- 30 hrs. between SCR regenerations, only takes 5-10 minutes to complete!
- VGT (Variable Geometry Turbocharger)



GRADE CONTROL TECHNOLOGY IMPROVES PRODUCTIVITY & ACCURACY

2D Machine Guidance (MG)

The 210 X4 can be fitted with the Link-Belt® 2D Machine Guidance (MG) system to help improve excavator operations on projects such as trenching for underground utilities and pipelines, digging footers and basements, site prep, building roads and mass excavation. Simply input the target depth, cross slope, and or mainfall slope required from the job and the system will provide visual and audible indication to help the operator maintain a desired grade thus eliminating under or over excavating.

2D MG leverages the existing machine monitor and eliminates clutter inside the cab. The 2D MG system also utilizes external inertial measurement unit (IMU) sensors to provide highly accurate guidance at a lower cost compared to “in-cylinder sensors”.

- Utilizes the machine monitor for all 2D MG operations.
- The 2D MG monitor indicates the position of the attachment relative to the target grade at all times providing the operator the information he needs without relying on a grade checker.
- Measurement mode enables the operator to use the excavator attachment as a precise measuring tool.
- Guidance mode displays depth, attachment angle, height & depth limitation alarm.
- Guidance system only, operator is in full control of the machine.
- Operators are up to 30% more productive with 2D MG compared to without technology.



2D Machine Control (MC)

The Link-Belt 2D Machine Control (MC) system enables operators to dramatically improve their productivity and accuracy while reducing their mental fatigue by automating the movement of the boom and bucket to keep the bucket cutting edge on the desired target grade. 2D MC is ideal for applications like trenching for underground utilities or pipelines or anything that requires the last pass to perfectly match the desired target grade whether it's a flat or sloping surface. The 2D MC system adds a 10" Android touchscreen display with an intuitive user interface and a machine control joystick in the cab to engage the semi-automatic boom and bucket control.

- Semi-automatic function intended for the last pass at the desired target grade, not for bulking out or mass excavation.
- The operator controls the speed of the stick while the boom and bucket automatically adjust to maintain the target grade.
- The operator is in full control and can override the semi-automatic function at all times.
- Operators can now create smooth, flat or sloped surfaces more easily when the excavator is placed in Autos mode.
- Operators are up to 30% more productive with 2D MC excavator automatics compared to a 2D MG system.





MORE ROOM, COMFORT AND CONTROL FOR OPERATORS

The X4 Series offers the most advanced and roomiest cab in its class. Comfortable, automotive-grade high-back seat with head rest provides superior lumbar back support. With a longer and wider seating surface, it reclines to a 155° maximum reclining angle to create a relaxed environment during breaks. Air-suspension seat is standard with tilting adjustment and seat heaters available as options.

The cab layout also includes ergonomically-designed arm rests that move with console, maintaining a constant distance between joysticks and arm rests no matter how the seat is adjusted.

- Quiet, pressurized cab
- Joysticks with easy-to-hold grip and switches
- Handy 'radio mute' and one touch wiper switch
- Optional proportional joysticks w/ auxiliary hydraulics control
- Cup holder and storage areas for cell phones and other small items
- Dual halogen cab lights standard
- Full time rear camera display
- Optional RH & LH side cameras
- ROPS and FOPS Level 1 certified, optional FOPS Level 2 head guard available
- Optional LED lights use less energy and are 3X brighter!
- Optional retractable rear window shade
- Optional front sun visor
- Improved radio with USB port and Bluetooth for hands-free communication.





High-Definition LCD monitor has a full-color 7" display that rivals the resolution found in luxury automobiles. Controls are easy to read and easy to use. The rear-view camera activates automatically whenever the machine is started, and sight guidelines have been added for increased safety.

- Anti-glare coating on screen
- Track up to 14 service maintenance reminders
- System/machine warning messages
- Monitor SCR auto regeneration
- Select and set up attachments: 5 presets for breakers; 5 presets for crushers
- In-cab pressure controls
- Anti-theft system
- Auto-adjusts for time and calendar
- 24 languages available

WAVESTM WIDE-ANGLE VISUAL ENHANCEMENT SYSTEM

For the ultimate in visibility, X4 machines can be fitted with the Wide Angle Visual Enhancement System - or WAVES for short. Using three closed-circuit cameras, this optional viewing system provides an unbelievable 270° visual coverage around the machine, eliminating any potential blind spots from the operator's line of sight. WAVES images can be displayed on the standard X4 monitor.

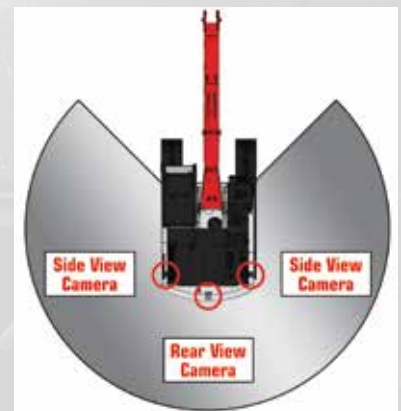



GET WORKING FAST WITH EASY ACCESS TO SERVICE POINTS

Maintenance is a snap, with ground level access to all routine service points, including batteries, fuel filters, engine oil filter, dual-element air filter and cab fresh air filter.

- Radiator screens are easy to remove and clean from ground level...no tools needed!
- A/C Condenser tilts for easy cleaning and maintenance
- Easy battery compartment access; 2 hand-turn knobs
- Improved battery disconnect switch with no keys needed
- Convenient ground-level sample ports in pump compartment
- Green drain plug and hose
- More data collection points
- Automatic door locking mechanism on side door
- Quick and easy access to grease all attachment pivot points
- Grease cylinder track adjusters make adjusting track tension a breeze
- New undercarriage side frame design enables easier cleaning
- In-cab reminders track 14 different maintenance procedures



TELEMATICS WITH NO SUBSCRIPTION FEE

RemoteCARE® lets you remotely monitor and track machine location, operational performance, working status and periodic maintenance requirements - now at no cost to you. It tracks and records both routine and major service intervals for your machines, giving you more flexibility and control when scheduling maintenance procedures. It also lets you be more proactive if potential failure conditions arise; whenever a diagnostic trouble code (DTC) is detected, a warning message appears on the machine display, and an e-mail alert is automatically sent to you. RemoteCARE also assists in theft prevention by offering 24/7 surveillance and geofencing capabilities.

FREE Subscription Includes:

- ✓ 24/7 Remote Monitoring and Security
- ✓ Machine Location
- ✓ Geo-fence & Curfew Range
- ✓ Actual Fuel Consumption
- ✓ Fuel Levels
- ✓ Hour Meter Reading
- ✓ Radiator Water Temperature
- ✓ Machine Working Time/Idle Time
- ✓ Attachment Working Hours
- ✓ Working Modes
- ✓ Service Maintenance Reminders
- ✓ Service Warnings



REMOTE CARE® APP

Manage your Link-Belt equipment with this user friendly telematics management tool with GPS technology. The RemoteCARE App provides timely and reliable machine utilization – as well as assisting in DTC notifications. With RemoteCARE you will be able to remotely monitor and track your machine's location, operational performance, and working status. Contact your local Link-Belt dealer for questions.

App features include...

- Machine location
- Fuel consumption
- Utilization report
- Fuel efficiency
- Analytical snapshots
- Idle rate
- DTC notification history
- Favorite list

Download Apple or Android app at lbxco.com/apps for phone and tablet.



BUILT STRONG TO HANDLE ANYTHING

210 X4 machines are more rugged and durable, with robust structural improvements to the boom & arm structures, along with improvements to lower frame and travel components.



Boom & Arm

- Improved boss shapes reduce stress on boom and arm pin
- Cast boom tip for increased reliability
- Stronger cylinder mounts



Lowers

- Thicker travel motor case - 8% increase
- Thicker plating between side frame and travel motor case - 14% increase
- Unique side-frame design reduces dirt accumulation and is easier to clean.
- 52% wider idler hub



CUSTOMER SUPPORT IS JUST A CALL AWAY

A network of Link-Belt Excavator dealers across the U.S. and Canada is waiting to serve you. Expect fast and dependable service, backed by 24/7 access to parts.

Exceptional Warranty Coverage

All X4 excavators purchased after July 1, 2020 are backed by a 5-year/5,000-hour Full Machine Warranty, 5-year/10,000-hour Structural Warranty, along with participation in the X4 Fluid Analysis Program for the duration of the warranty (free with all X4 machines). Extended warranty coverage packages are also available.

Contact your dealer for complete details.



SPECIFICATIONS



Engine

Isuzu AR-4HK1X Final Tier 4 turbocharged diesel engine with electronic control (ECM) and high pressure common-rail fuel injection, 4-cylinder, water-cooled, Cooled Exhaust Gas Recirculation (CEGR), Intercooler, Variable-Geometry Turbocharger (VGT), Diesel Oxidation Catalyst (DOC) and Selective Catalytic Reduction (SCR) system with Dosing Control Module and heated DEF lines and tank. Electronic fuel pump and priming, Fuel cooler, Auto-idle start, Auto warm-up, EPF engine protection, dual-stage fuel filtration, remote oil filter, engine oil sample port, green plug oil drain, double element air filter.

SAE J 1349 net horsepower.....	160 hp (119.3 kW) @ 1,800 rpm
Displacement.....	317 cu in (5.2 L)
Maximum Torque.....	457 lbf-ft (620 Nm) @ 1,600 rpm
Starter.....	24V-5.0kW
Alternator.....	50 amp
Battery.....	(2) 12-volt 92 amp hours



Cab and Controls

ROPS and FOPS Level 1 certified with automatic climate control A/C and heat with defroster, 7" LCD Hi-Definition color monitor with full time rear view camera display, fuel efficiency gauge, low-effort joysticks are pre-wired for auxiliary hydraulics, dual cab lights, control pattern changer, safety glass windows, sunroof with sunshade, shockless cab suspension with four fluid cab mounts, SCM High-Back reclining air-suspension seat, sliding 4-position tilting control consoles, Bluetooth technology, AM/FM sound system with USB and MP3 auxiliary input jack, digital clock, dome light, seat belt, coat hook, cup holder, storage compartments, floor mat, footrests, ashtray, 24V cigarette lighter, 12V outlet, travel alarm, handrails, mirrors, side-entry cab filter, spare parts kit.

Three selectable work modes, RemoteCARE Telematics GPS system, anti-theft password protection system, onboard self-diagnostic system with memory and service interval reminders, auto idling system, one-touch decelerator, auto-idle engine shutdown, auto-power boost, neutral safety start, gate-lock safety shutoff.



Hydraulic System

Open-center system, two variable-displacement electronically controlled axial-piston pumps and one gear pump for pilot controls, main control valve with one 4-spool section and one 5-spool section with auxiliary spool: stackable, Auxiliary Control System, oil cooler, Auto-Power boost, anti-drift valves, 6 micron return filter, firewall, hydraulic oil sample port.

Hydraulic Pumps

Pump Output.....	2 x 55.7 gpm (211 L/min)
Pilot Pump Maximum Flow.....	4.8 gpm (18 L/min)

Relief Valve Settings

Boom/Arm/Bucket.....	4,970 psi (34.3 MPa)
in Power Boost.....	5,410 psi (37.3 MPa)
Swing Circuit.....	4,260 psi (29.4 MPa)
Travel Circuit.....	4,970 psi (34.3 MPa)

Hydraulic Cylinders

	number of cylinders - bore x rod x stroke
Boom.....	2 - 4.7" x 3.3" x 49.4" (120 mm x 85 mm x 1,255 mm)
Arm.....	1 - 5.5" x 3.9" x 57.5" (140 mm x 100 mm x 1,460 mm)
Bucket.....	4.7" x 3.3" x 39.8" (120 mm x 85 mm x 1,010 mm)



Swing

Planetary reduction powered by axial-piston motor, Internal ring gear with grease cavity for swing pinion, Swing bearing is single-row, shear type ball bearing, Mechanical disc swing brake, Auto-power swing.

Swing Speed.....	11.5 rpm
Tail Swing.....	9' 2"(2.79 m)
Swing Torque.....	47,200 lbf-ft (64.0 kNm)

Undercarriage

X Pattern carbody with 14' 8"(4.47 m) LC long undercarriage by 7' 10"(2.39 m) track gauge, Sealed and strutted track chain with track guide, Sealed rollers and idlers, Two-speed independent hydrostatic travel with compact planetary final drive, Disc type brakes, Adjustable track tension, Carbody belly pan.

Carrier Rollers.....	2 per Side
Track Rollers.....	8 per Side
Track Link Pitch.....	7.48"(190 mm)
Shoes.....	49 per Side
Shoe Width.....	31.5"(800 mm)
Ground Pressure.....	4.93 psi (0.034 MPa)



Travel System

Two-speed independent hydrostatic travel with compact axial-piston motors, Hydraulic motor powered output shaft coupled to a planetary reduction drive and track sprocket, All hydraulic components mounted within the width of side frame, Automatic downshift for high torque to overcome obstacles, Spring-applied hydraulic release parking brake built into each motor, Travel motors equipped with counterbalance valve to prevent over-speeding down an incline.

Travel Speeds.....	2.1 - 3.5 mph (3.4 - 5.6 km/h)
Drawbar Pull.....	42,300 lbf (188 kN)
Gradeability.....	70% (35°)



Attachment

Boom.....	18' 8"(5.70 m)
Available Arms	Digging Force
• 9' 8"(2.94 m).....	23,100 lbf (103 kN)
with Auto Power Boost.....	25,100 lbf (112 kN)
• 7' 10"(2.40 m).....	27,600 lbf (123 kN)
with Auto Power Boost.....	30,000 lbf (133 kN)
• Bucket Digging Force.....	31,800 lbf (142 kN)
with Auto Power Boost.....	34,600 lbf (154 kN)



Lubricant & Coolant Capacity

Fuel Tank.....	108 Gallons (410.0 Liters)
Hydraulic System.....	66 Gallons (250.0 Liters)
Hydraulic Tank.....	39 Gallons (147.0 Liters)
Final Drive (per side).....	1.3 Gallons (5.0 Liters)
Swing Drive.....	1.3 Gallons (5.0 Liters)
Engine Oil.....	6.1 Gallons (23.1 Liters)
DEF Tank.....	31.7 Gallons (120.0 Liters)
Coolant System.....	8.3 Gallons (31.4 Liters)



Operating Weight

Working weight with 31.5"(800 mm) shoes, 18' 8" (5.70 m) boom, 9' 8"(2.94 m) arm, 1,435 lb. (651 kg) bucket, 8,640 lb. (3 920 kg) counterweight.....	48,900 lbs. (22 200 kg)
--	-------------------------

WORKING RANGE & TRAVEL DIMENSIONS

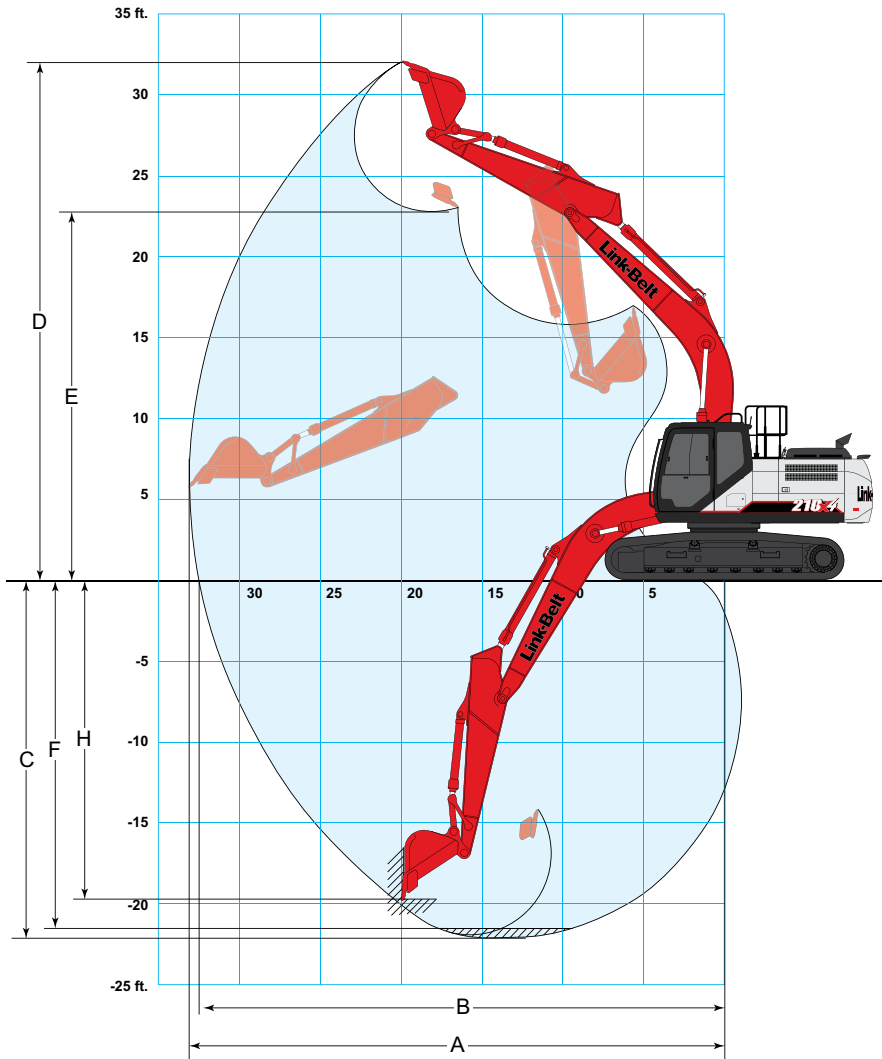

Machine Equipped with 18' 8" (5.70 m) Boom	Arm 9' 8" (2.94 m)	Arm 7' 10" (2.40 m)
A. Maximum reach	32' 6" (9.90 m)	30' 11" (9.42 m)
B. Maximum reach @ ground level	31' 11" (9.73 m)	30' 4" (9.24 m)
C. Maximum dig depth	21' 10" (6.65 m)	20' 1" (6.11 m)
D. Maximum dig height	31' 6" (9.61 m)	30' 10" (9.39 m)
E. Maximum dump height	22' 4" (6.81 m)	21' 7" (6.59 m)
F. Digging depth 8' (2.44 m) level bottom	21' 3" (6.47 m)	19' 4" (5.90 m)
G. Bucket rotation	177°	177°
H. Maximum vertical wall depth	19' 7" (5.96 m)	18' 0" (5.48 m)

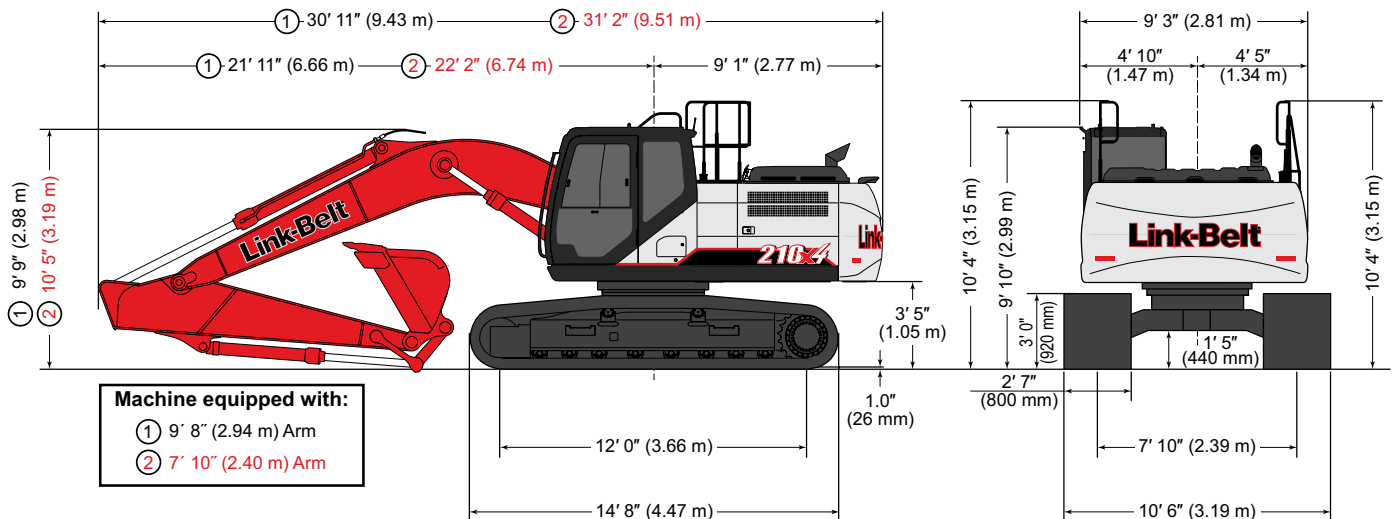

LIFT CAPACITIES

Radius of Load															
9' 8" (2.94 m) Arm with 18' 8" (5.70 m) Boom and 1,450 lb. (650 kg) Bucket with Power-Boost Applied															
End	Side	5' 0" (1.5 m)		10' 0" (3.0 m)		15' 0" (4.5 m)		20' 0" (6.0 m)		25' 0" (7.5 m)		30' 0" (9.0 m)		Cap at Max. Reach	
		End	Side	End	Side	End	Side	End	Side	End	Side	End	Side	End	Side
+25' 0"	lbs									5,100*	5,100*			5,000*	5,000*
(7.5 m)	kg									2 960*	2 960*			2 260*	2 260*
+20' 0"	lbs									8,550*	7,850			4,750*	4,750*
(6.0 m)	kg									3 940*	3 660			2 150*	2 150*
+15' 0"	lbs							10,300*	10,300*	9,800*	7,600	5,700*	5,400	4,700*	4,700*
(4.5 m)	kg							4 760*	4 760*	4 490*	3 550	3 180*	2 530	2 140*	2 140*
+10' 0"	lbs			22,500*	22,500*	16,500*	16,350	12,700*	10,550	10,700*	7,300	8,300*	5,300	4,850*	4,850
(3.0 m)	kg			10 500*	10 500*	7 670*	7 580	5 880*	4 900	4 930*	3 400	3 870	2 460	2 210*	2 200
+5' 0"	lbs			20,300*	20,300*	20,550*	15,450	14,850*	9,950	11,000	7,000	8,150	5,100	5,200*	4,750
(1.5 m)	kg			8 580*	8 580*	9 540*	7 180	6 860*	4 630	5 110	3 250	3 790	2 390	2 350*	2 150
Ground	lbs			18,950*	18,950*	22,800*	14,600	15,200	9,500	10,700	6,700	7,650*	5,000	5,700*	4,900
Line	kg			8 330*	8 330*	10 540*	6 780	7 080	4 410	4 970	3 130	3 730	2 330	2 600*	2 220
-5' 0"	lbs	16,400*	16,400*	24,400*	24,400*	23,200*	14,350	14,950	9,250	10,550	6,600			6,650*	5,350
(1.5 m)	kg	7 490*	7 490*	10 770*	10 770*	10 710*	6 660	6 960	4 300	4 910	3 070			3 010*	2 430
-10' 0"	lbs	22,300*	22,300*	33,500*	28,750	22,550*	14,500	15,050	9,350	10,700	6,750			8,400*	6,350
(3.0 m)	kg	9 960*	9 960*	14 770*	13 430	10 420*	6 730	6 990	4 340	4 980	3 130			3 790*	2 860
-15' 0"	lbs	31,500*	31,500*	28,900*	28,750	19,900*	14,950	14,100*	9,850					11,850*	8,500
(4.5 m)	kg	13 990*	13 990*	13 430*	13 390*	9 260*	6 940	6 630*	4 550					5 360*	3 790

Radius of Load															
7' 10" (2.40 m) Arm with 18' 8" (5.70 m) Boom and 1,550 lb. (700 kg) Bucket with Power-Boost Applied															
End	Side	5' 0" (1.5 m)		10' 0" (3.0 m)		15' 0" (4.5 m)		20' 0" (6.0 m)		25' 0" (7.5 m)		30' 0" (9.0 m)		Cap at Max. Reach	
		End	Side	End	Side	End	Side	End	Side	End	Side	End	Side	End	Side
+25' 0"	lbs							8,700*	8,700*					7,400*	7,400*
(7.5 m)	kg							3 510*	3 510*					3 340*	3 340*
+20' 0"	lbs							10,250*	10,250*	9,400*	7,600			7,000*	6,750
(6.0 m)	kg							4 670*	4 670*	4 320*	3 550			3 170*	3 020
+15' 0"	lbs					13,600*	13,600*	11,300*	10,850*	10,450*	7,400			6,950*	5,700
(4.5 m)	kg					6 320*	6 320*	5 240*	5 020	4 840*	3 460			3 140*	2 580
+10' 0"	lbs					17,950*	16,250*	13,500*	10,300	11,100	7,150			7,150*	5,250
(3.0 m)	kg					8 230*	7 530	6 240*	4 780	5 150	3 320			3 240*	2 370
+5' 0"	lbs					21,300*	15,050	15,400	9,750	10,800	6,850			7,550*	5,100
(1.5 m)	kg					9 810*	6 990	7 120*	4 530	5 040	3 180			3 430*	2 320
Ground	lbs			17,000*	17,000*	23,100*	14,400	15,050	9,350	10,600	6,650			8,350*	5,300
Line	kg			7 480*	7 480*	10 680*	6 680	7 010	4 340	4 920	3 080			3 780*	2 400
-5' 0"	lbs	18,050*	18,050*	25,150*	25,150*	23,050*	14,300	14,900	9,200	10,550	6,600			9,400	5,900
(1.5 m)	kg	8 040*	8 040*	11 120*	11 120*	10 640*	6 650	6 940	4 280	4 900	3 060			4 260	2 670
-10' 0"	lbs	25,150*	25,150*	31,800*	29,000	21,850*	14,550	15,050	9,400					11,450	7,200
(3.0 m)	kg	11 250*	11 250*	14 690*	13 510*	10 090*	6 770	7 000	4 360					5 140	3 230
-15' 0"	lbs			25,950*	25,950*	18,100*	15,100							12,050*	10,200
(4.5 m)	kg			12 080*	12 080*	8 460*	7 020							5 500*	4 530

Notes: Excavator lifting capacities

- Lifting capacities shown should not be exceeded. Weight of all lifting accessories must be deducted from the above lifting capacities.
- Lifting capacities are based on machine standing on firm, uniform supporting surface. User must make allowances for job conditions such as soft or uneven ground.
- Lifting capacities shown do not exceed 75% of minimum tipping loads or 87% of hydraulic capacities. **Capacities marked with an asterisk (*) are limited by hydraulic capacities.**
- Least stable position is over the side.
- Operator should be fully acquainted with the Operator's Manual & Operating Safety Booklet, furnished by LBX before operating the machine.
- Capacities apply only to the machine as originally manufactured and normally equipped by LBX Company, LLC.
- Lift capacity ratings are based on ISO 10567, "Earthmoving Machinery - Hydraulic Excavators - Lift Capacity."

STANDARD & OPTIONAL EQUIPMENT

STANDARD EQUIPMENT

CAB

- 12V Power Outlet
- AM/FM Sound System
- Anti-Theft Device
- Auxiliary Switches on Control Lever
- Bluetooth
- Cab Filter - External
- Cab Handrails
- Cab Interior Light
- Cab ISO-Mounts
- Cab Light (2)
- Clear Roof Window
- Climate Control A/C and Heater
- Cup Holder
- Defroster
- Digital Clock
- Emergency Exit and Hammer
- Face Vent
- Floor Mat
- FOPS Level 1 Certified
- Front Window One-Touch Lock
- Gate Lock Hydraulic Activation
- Horn
- Hour Meter (Digital)
- LCD Color Monitor
- Magazine Storage Rack
- Maintenance Interval Reminders
- MP3 Auxiliary Input Jack
- On-Board Diagnostic System
- One-Piece Right Window
- Radio Mute Switch
- Rear View Camera
- Rear View Mirrors (2)
- RemoteCARE Support System (GPS)
- Roof Sun Shade
- ROPS Certified Structure
- Safety Glass Windows
- SCM Air-Suspension Seat
- Seat Recline
- Selectable Monitor Languages
- Small Storage
- Travel Alarm with Cancel Switch
- Trip Meter (Digital)
- USB Input
- Wiper & Washer
- Wiper Switch on RH Joystick

ENGINE

- 50A Alternator
- Air Filter (Double Element)
- Air Filter Restriction Indicator
- Auto Warm-Up System
- Auto-Idle
- Auto-Idle Engine Shutdown

- Battery Disconnect Switch
- CEGR (Cooled Exhaust Gas Recirculation)
- Cooling Fan
- Diesel Oxidation Catalyst (DOC)
- Drain for Fuel Tank
- Dual Remote Fuel Filters with Water Separators
- EGR Coolers
- Emergency Engine Stop
- Engine Idle System
- Engine Oil Sample Port
- Engine Protection Feature
- External Fuel Gauge
- External DEF Gauge
- Fan Housing
- Fuel Cooler
- Fuel Filter Restriction Indicator
- Fuel Management System
- Fuel Shut-Off Valve
- Fuel Usage History
- Fuel Usage Monitor
- Glow Plug Pre-Heat
- Idle-Start
- Intercooler
- Neutral Start
- One-Touch Idle
- Passive Emissions Regeneration
- Radiator / Oil Cooler / Intercooler Protective Screen
- Remote Engine Oil Drain
- Remote Oil Filter
- Selective Catalytic Reduction (SCR)
- DEF Gauge on Monitor
- VGT Turbocharger

HYDRAULICS

- Arm Regeneration
- Arm Speed Assistance (2 Pump Flow)
- Attachment Cushion Valve
- Auto Swing Priority
- Auxiliary Flow Control
- Auxiliary Tool Settings (Memory)
- Auxiliary Valve
- Boom Regeneration
- Boom Speed Assistance (2 Pump Flow)
- Bucket Curl Assist
- Control Levers Pre-Wired for Auxiliary Hyd.
- Control Pattern Changer (2 way)
- Electronically Controlled Hydraulic Pumps
- Fire Wall
- Free Swing
- Holding Valve (Arm & Boom)
- Hydraulic Filter Restriction Indicator
- Hydraulic Oil Sample Port
- Long Life Hydraulic Oil (5,000 Hour)

- Neutral Pump De-Stroke
- Oil Cooler
- Power Boost
- Power Save
- Pressure Reading on Monitor
- Pump Stand-By Pressure
- Single Pedal Travel
- Straight Travel Circuit

UNDERCARRIAGE

- 800 mm (31.5" in) 3-Bar Steel Grousers
- Carbody Belly Pan (Swivel Guarding)
- Center Track Guide (single)
- Lashing Points (Tie-Downs)
- Long Undercarriage
- Sealed Link Chain
- Steps
- Strutted Track Chain
- X-Pattern Carbody

UPPERSTRUCTURE

- Belly Pans
- Center Cover (Over Main CV)
- Fuel Tank Belly Pan
- Hand Rail (RH access)
- ISO Guard Rails
- Lifting Eyes for Counterweight
- Lockable Fuel Cap and Service Doors
- Lockable Tool Box
- Turntable Tub
- Work Lights (Boom and Tool Box)

ATTACHMENT

- 18' 8" (5.70 m) Main Boom Section
- Auxiliary Pipe Brackets
- Boom Work Light
- Bucket Anti-Clatter Device
- Chrome Pins
- Easy Maintenance System (EMS)
- Remote Lube Bank
- Teardrop Pin Retention Keepers

PARTS KIT

- Bucket Anti-Clatter Device
- Engine Manual
- Engine Oil Filter
- Filter Wrench
- Fuel Filters
- Grease Gun
- Green Plug Drain Hose for Engine Oil Drain
- Hydraulic Return Filter
- Ignition Keys
- Pilot Circuit Hydraulic Filter
- Rearview Mirrors
- Work Light for Boom

OPTIONAL EQUIPMENT

CAB

- 270° WAVES™ Camera System
- Cab Light (2 LED)
- Cab Sun Screen [rear]
- FOPS Head Guard (Level 2)
- Front Guard (Mesh)
- Front Guard (OPG 1,2)
- LED Light Kit for Side Camera (1)
- LED Lights for Rear Camera (2)
- Rain Deflector
- SCM Air-Suspension Seat with Tilt & Heater

ENGINE

- 85A Alternator
- Air Pre-Cleaner (Cyclone type)
- Refuel Pump
- Reversible Cooling Fan
- Tropical Package

HYDRAULICS

- Hose Burst Check Valve
- Proportional Hydraulic Controls

AUXILIARY HYDRAULIC OPTIONS

- Single-Acting Aux. w/ Proportional Joysticks
- Multi-Function Aux. w/ in-cab pressure setting control
- Thumb Aux. w/ Proportional Joysticks
- Combination Aux. w/ in-cab pressure setting control

UNDERCARRIAGE

- 600 mm (23.5" in) 3-Bar Steel Grousers
- 700 mm (27.5" in) 3-Bar Steel Grousers
- Center Track Guide (triple)

UPPERSTRUCTURE

- Full-Length Steel Triangulated Side Guards
- Rubber Bumper Guards

ATTACHMENT

- 7' 11" (2.40 m) Short Arm
- 9' 8" (2.94 m) Arm
- HD Bucket Linkage
- Quick Couplers
- Thumbs

Bucket Sizes

Bucket Type	SAE Heaped Capacity		Width Outside Lip		Bucket Weight		Number of Teeth	Arm Length	
	(yd ³)	(m ³)	(in)	(mm)	(lbs)	(kg)		9' 8" 2.94 m	7' 11" 2.41 m
STDP Standard duty plate	0.65	0.50	24	610	1151	522	4	H	H
	0.87	0.67	30	762	1265	574	4	H	H
	1.09	0.83	36	914	1433	650	5	H	H
	1.31	1.00	42	1067	1570	712	5	M	H
	1.53	1.17	48	1219	1687	765	5	L	M
HDP Heavy duty plate	1.75	1.34	54	1372	1853	841	6	L	L
	0.64	0.49	24	610	1392	631	3	H	H
	0.85	0.65	30	762	1592	722	4	H	H
	1.07	0.82	36	914	1794	814	5	H	H
	1.29	0.99	42	1067	1954	886	5	M	M
XDP Extreme duty plate	1.51	1.15	48	1219	2114	959	5	L	M
	1.72	1.32	54	1372	2315	1050	6	L	L
	0.64	0.49	24	610	1549	703	3	H	H
	0.85	0.65	30	762	1769	802	4	H	H
	1.07	0.82	36	914	1933	877	4	H	H
POWER HDP for use with ESCO multi-pin grabber only	1.29	0.99	42	1067	2152	976	5	M	M
	1.51	1.15	48	1219	2316	1051	5	L	M
	1.72	1.32	54	1372	2536	1150	6	L	L
	0.61	0.47	24	610	1956	887	4	H	H
	0.80	0.61	30	762	2102	953	4	H	H
DITCH	0.99	0.76	36	914	2287	1037	5	H	H
	1.18	0.90	42	1067	2433	1104	5	M	M
	1.38	1.06	48	1219	2578	1169	5	L	M
	1.08	0.83	60	1524	1470	667	0	H	H
	1.20	0.92	66	1676	1557	706	0	H	H
	1.32	1.01	72	1829	1648	748	0	M	H

Approval Code For Arm/Bucket Combinations	
H.....	Heavy material (up to 3,370 lbs./yd ³)
M.....	Medium material (up to 2,700 lbs./yd ³)
L.....	Light material (up to 2,020 lbs./yd ³)
N/A.....	Not applicable

STDP.....	Standard duty plate
HDP.....	Heavy duty plate
XDP.....	Extreme duty plate
POWER.....	HDP for use with ESCO multi-pin grabber only

Litho in USA 8/20 #LBX2429 supersedes #LBX2390

LBX® and Link-Belt® are registered trademarks. Copyright 2020. All rights reserved. We are constantly improving our products and therefore reserve the right to change designs and specifications.